

Diocese of Edinburgh

Scottish Episcopal Church



Updated October 2025

WELCOME TO THE DIOCESE OF EDINBURGH



A welcome booklet containing useful information about the Diocese of Edinburgh and the Scottish Episcopal Church for incoming clergy new to the Diocese or the SEC.



Introduction

The Diocese of Edinburgh is one of seven dioceses which make up the province of the Scottish Episcopal Church (SEC). The SEC itself is one of 44 provinces and churches which make up the 80 million membership of the Anglican Communion across the world. If you have come from other dioceses, provinces or churches, we are delighted to welcome you to the diocese. It is likely that you will have engaged in some research about Edinburgh diocese before your arrival. You may already be aware of some of the differences between where you came from and this diocese. However, some people joining the SEC from other provinces in particular have previously commented that some of these differences did not actually become apparent until they were in post! We hope this booklet will be a helpful way of providing you with some practical information, including several key differences/areas to note.

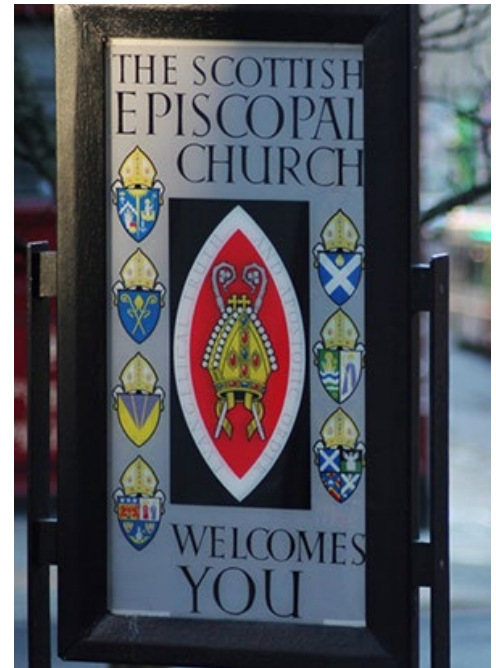

Contents

| | |
|--|----------|
| Diocesan Structures and People | 4 |
| Bishop | 4 |
| Dean | 4 |
| Diocesan Officials..... | 4 |
| Committee Conveners | 5 |
| Diocesan Office..... | 5 |
| Cathedral | 6 |
| Diocesan Synod..... | 6 |
| Area Councils | 6 |
| Standing Committee | 7 |
| Linked Dioceses | 7 |
| Beyond the Diocese | 8 |
| Dioceses in the SEC | 8 |
| College of Bishops..... | 8 |
| General Synod | 8 |
| Code of Canons and Digest of Resolutions | 8 |

| | |
|--|-----------|
| The Anglican Communion | 9 |
| Ecumenical Work | 9 |
| Church and State | 9 |
| Local..... | 10 |
| Your Charge | 10 |
| Vestry | 10 |
| Worship..... | 12 |
| Aspects of Inclusion | 12 |
| Children and Young People..... | 13 |
| Diocesan Youth Work | 13 |
| Play Church | 13 |
| Schools Work | 13 |
| Provincial Youth including PYC and ‘Yeek’..... | 13 |
| Occasional Offices | 15 |
| Weddings..... | 15 |
| Funerals | 15 |
| Baptisms | 16 |
| Expenses for Occasional Offices..... | 16 |
| Administrative..... | 17 |
| Registers | 17 |
| Congregation Roll | 17 |
| Annual Returns | 17 |
| Canon 35/Buildings..... | 17 |
| Safeguarding..... | 17 |
| GDPR..... | 17 |
| Support from the Diocesan Office..... | 17 |
| Ministerial Support..... | 19 |
| Buddy..... | 19 |
| Continuing Ministerial Development (CMD) | 19 |
| Ministerial Review | 19 |



Diocesan Structures and People

THE BISHOP



We currently have a Vacancy-in-See. Our Interim Bishop is Bishop Mark Strange, who is Bishop of Moray, Ross, and Caithness, and Primus. During this vacancy, concerns or queries should be directed in the first instance to The Dean (see below) or via the Bishop's PA, Hannah Marcus:

BishopsPA@dioceseofedinburgh.org.

If you want to learn more about our Episcopal Election process, please visit our website: <https://edinburgh.anglican.org/bishop-search/>.

THE DEAN

The Very Revd Frances Burberry, Diocesan Office, 21a Grosvenor Crescent, Edinburgh EH12 5EL. Tel: 0131 315 0404. Mobile: 07803 602394. Email: dean@dioceseofedinburgh.org

Each diocese of the Scottish Episcopal Church has a Dean who is appointed by the Bishop of the diocese. The Dean is a priest within the diocese who, rather than heading the cathedral staff, assists the Bishop in the administration of the diocese and undertakes various canonical duties. Frances serves as Rector of St Ninians's, Comely Bank, and is also an Honorary Chaplain to the University of Edinburgh. She can be contacted at any time and welcomes each and every opportunity to meet up for a coffee and a chat, or a meal out.



DIOCESAN OFFICIALS

There are four Diocesan Officials, who are as follows:

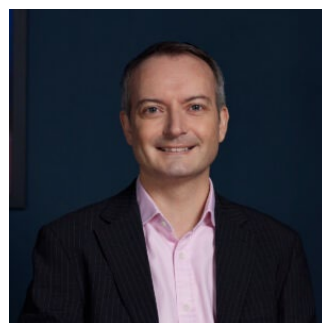

- **Diocesan Secretary:** Prof Wilson Poon, diosec@dioceseofedinburgh.org.
- **Chancellor:** Gavin McEwan WS.
- **Registrar:** Pippa Snell.
- **Treasurer:** Ian Lawson, treasurer@dioceseofedinburgh.org.

COMMITTEE CONVENORS

There are two main and separate committees in the Diocese: **Finance and Management**, and **Mission and Ministry** (aka DMMC). The convenor of Finance and Management is Robert O’Riordan and the convenor of Mission and Ministry is the Revd Canon Dr Sophia Marriage, who is the rector of St Mark’s in Portobello. Both these committees report to Standing Committee, of which the Bishop is Convenor.



Each main committee has pendant committees.

Finance and Management:

- Buildings Committee (convened by Alex Stewart)
- Personnel Committee (convened by the Revd David Todd)

Mission and Ministry:

- International Committee (convened by the Revd Nicky McNelly)

THE DIOCESAN OFFICE

Edinburgh Diocesan Office is staffed by a small team of full- and part-time staff; there may be fewer than you are used to. The role of the Diocesan Office is to support the work of the Bishop and the Diocese. The office is located at 21a Grosvenor Crescent EH12 5EL, and is open Monday – Friday for enquiries. Tel: 0131 538 7033. Email: office@edinburgh.anglican.org

The office team consists of:

- The Bishop (when not in vacancy)
- Dean Frances
- Hannah Harcus – PA to Bishop and Dean, and Diocesan Protection Officer
- Simon Filsell – Diocesan Administrator
- Caroline Miller – Finance and Support Officer
- Mollie Nijam – Diocesan Communications Co-ordinator (on maternity leave)
- Revd Fee Reynolds – Advisor for Christian Life

We currently have one temporary, part-time member of staff:

- Cathy Tingle – Communications Officer and Administrative Assistant (DMMC)

There are no departments and many of the staff work part time. They are supported by clergy and lay people from around the Diocese volunteering to run various programmes.

There is lots of information and templates on our website: <https://edinburgh.anglican.org/>.

Clergy who enjoy working in Scotland are usually those who are happy to contribute as a Committee or Board member, either provincially or within the diocese, in addition to their church responsibilities. Information about people, Committees, Boards, etc, can be found in the Provincial ‘Red Book’. You may be able to find one in your church, but if not, you can buy one at the General Synod Office. It is probably worth buying a new one, as they are updated every year, shortly after General Synod meets in June.



THE CATHEDRAL

St Mary's Cathedral, Palmerston Place, Edinburgh EH12 5AW

Tel: 0131 225 6293 Email: office@cathedral.net Website: www.cathedral.net

(Not to be confused with the Roman Catholic (Metropolitan) Cathedral in Edinburgh which is also called St Mary's at 61 York Place, Edinburgh EH1 3JD)



The Provost of the Cathedral is the Very Revd John Conway, and the Vice Provost is the Revd Canon Dr Marion Chatterley (the SEC does not have Deans of Cathedrals). The Cathedral has a resident choir with young choristers (educated at St Mary's Music School) and lay clerks. There are events at the Cathedral for the whole Diocese at different points in the year, e.g. Holy Week when we meet to renew our Ordination Vows and collect the oils of Chrism and Healing.

DIOCESAN SYNOD

Twice a year we meet for Diocesan Synod, usually in Edinburgh. The first tends to be a Saturday in February/March while the second is usually an evening in October which is concerned with Finance. All clergy who are Instituted as a Rector, or hold a Licence or a Commission, are members of the Diocesan Synod. You are **required** to attend its meetings, unless you have permission from the Bishop to be absent. It is a good place to get to know other clergy from the Diocese. Your Lay Representative also attends, and will usually report back any news to the Vestry and congregation. See Canon 50 for more information on Diocesan Synod.



When there is a Vacancy-in-See, the Diocesan Synod forms the Electoral Synod, which appoints the next Bishop. All members of the Diocesan Synod therefore become members of the Electoral Synod; however, the membership is fixed at the Electoral Synod's first meeting. This means that if your congregation's Alternative Lay Representative attends that first meeting, they remain part of the Synod throughout. More details on this process are in Canon 4.

SYNOD CLERK

The Revd Canon Liz O'Ryan (Rector of Holy Trinity, Haddington), synodclerk@dioceseofedinburgh.org.

The Synod Clerk is voted for by Synod's House of Clergy and serves for 5 years; Liz took office in autumn 2025. Whilst she recognises that the 'Clerk' part of the role means paperwork, she is particularly drawn by the 'Synod' aspect, i.e. supporting all members of Synod in their roles and ministry.



AREA COUNCILS

The Diocese is divided into Area Councils. Each area consists of about 6 Charges. Some are regional, for example, the Borders, while the city ones are like wedges in a cake. Area Councils are attended by all clergy plus Lay Reps and sometimes the Treasurer or another member of the Vestry. Area Councils generally meet between 2 and 4 times a year, often just before Synod to discuss the upcoming business. Your Area Council may want to raise a particular point relevant to your area at Synod.

The clergy from an Area Council may choose to meet at other times for socials / mutual support in addition to the full Council meetings. We do not have Deanery Chapters in the SEC and while the Area Council is different, it is probably the nearest equivalent.

STANDING COMMITTEE

The Standing Committee carry on the business of the Diocesan Synod between meetings and are also the designated charity trustees for the Diocese (our charity number is SC001214). Many of the members are there *ex officio*, although there are also members who are elected directly by Synod for a period of 4 years (extendable for a second term only). The Standing Committee consists of:

- The Bishop
- The Dean
- The Diocesan Secretary
- The Registrar
- The Treasurer
- Convenor of Finance and Management Committee
- Convenor of Mission and Ministry Committee
- 2 x elected clergy (currently the Revd Rosie Addis and the Revd David Dixon)
- 2 x elected laity (currently Dr Michael Wood and Mr Philip Sawyer)

LINKED DIOCESES

As a founder member of the Porvoo Communion of Churches, we have strong links with Nordic and Baltic Lutheran Churches. We also have links with German and French Protestant Churches through other agreements. This document explains some of the different agreements the SEC has with other denominations in Scotland and around the world: <https://www.scotland.anglican.org/wp-content/uploads/SEC-guidelines-on-ecumenical-relations-final-01.2023.pdf>.

Edinburgh Diocese is linked with the Dioceses of Espoo (Evangelical Lutheran Church of Finland), Cape Coast (Ghana), and Dunedin (New Zealand).



Beyond the Diocese

DIOCESES IN THE SEC

The SEC is made up of seven different dioceses:

- Edinburgh
- Glasgow and Galloway
- St Andrews, Dunkeld and Dunblane
- Brechin
- Moray, Ross and Caithness
- Argyll and the Isles
- Aberdeen and Orkney.



COLLEGE OF BISHOPS

We do not have an Archbishop and this is a point that often escapes newcomers. The metropolitan authority is carried by the College of Bishops (the seven dioceses together). They elect a Primus to be their spokesperson and to represent the Province internationally. The Primus has no jurisdiction within any diocese other than his or her own. Thus, it is correct, when praying within the liturgy, to name your diocesan bishop first. If you wish you may also pray for the whole College of Bishops including the bishop serving as Primus, after your own bishop.

GENERAL SYNOD

General Synod is held in June and involves the whole province congregating (usually in Edinburgh), to discuss Provincial matters, often including governance and the canons (see below). The General Synod Office is located directly above Edinburgh Diocesan office, and is responsible both for the smooth running of General Synod, and the implementation of Synodical decisions and structures. You are not a member of General Synod until you are either nominated (for up to 2 consecutive terms of 4 years) or hold a post which gives you automatic membership (such as Chair of a Provincial Committee). See Canon 52 for more information on General Synod.

CODE OF CANONS AND DIGEST OF RESOLUTIONS

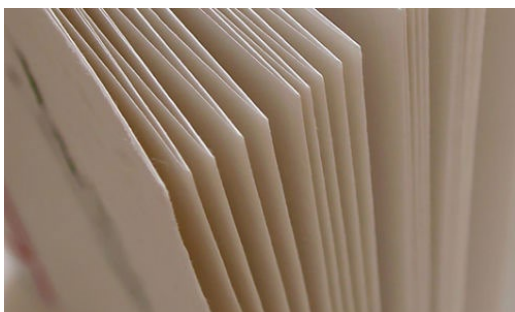

The Code of Canons provides the legal framework for the Scottish Episcopal Church. The Code is a living document and Canons can be edited, added, or removed annually at the General Synod. The General Synod can also pass resolutions to provide for operation of the Canons and internal regulation. These resolutions are contained within the Digest of Resolutions.

Your charge may have a copy of the Code of Canons. It often comes in the form of a ring-binder with paper inserts. It does go out of date from time to time as canons are updated so it is best to consult the online version: <https://www.scotland.anglican.org/who-we-are/publications/code-of-canons>

The Canons include information on Vestry responsibilities (60), rules about marriage (31), changes to your church building (35), organisational issues concerning Incumbencies, Joint Incumbencies and Linked Charges (36), etc. There is a comprehensive index at the back and the online version is searchable.

THE ANGLICAN COMMUNION

The Scottish Episcopal Church is a province of the Anglican Communion and this membership is important to us. The Province is strongly committed to the life of the global Anglican Communion. There is a particularly strong bond between the SEC and the Episcopal Church in the USA. It was Scottish Bishops who consecrated Samuel Seabury, the first Bishop of the Episcopal Church in the USA, in 1784, helping to shape the Anglican Communion as a family network of independent provinces.



ECUMENICAL WORK

The SEC seeks to work closely with all Christian denominations and has recently signed a partnership agreement with the Church of Scotland (the Saint Andrew Declaration). It is a member of the Scottish Christian Forum (the successor to ACTS), Churches Together in Britain and Ireland (CTBI), the Conference of European Churches, and the World Council of Churches. These links provide opportunities to work in partnership across many nations.

CHURCH & STATE

It can feel very different to operate in a Church that is completely separate from the state. This, of course, is not at all exclusive to the SEC within the Anglican Communion, but if you have come from the CofE, it might just take a bit of getting used to. SEC Bishops are elected and appointed without any state involvement, and the SEC is small, with both the Church of Scotland and the Roman Catholic Church in Scotland being larger. Once you have got used to being in a 'minority' church, you may find that it has some advantages, e.g. it can be much easier for the people and churches in the Province to relate to one another.



YOUR CHARGE

As in many other places, your incumbency is also known as a *charge* and a charge is a congregation or group of congregations.

We do not have a 'Parish' as such, but we do have canonical areas and a geographical presence. However, your baptisms and funerals are more likely to be for people who have been part of the congregation or have an association with the SEC. The SEC is not the "default option" that the CofE can sometimes be, and this will have implications for thinking about mission in your context. This does not, of course, mean that reaching out to and serving the community is any less important than it would be if there were a parish system.



THE VESTRY

The Vestry is the SEC version of a Parochial Church Council; there are many similarities but some important differences. The SEC website has a good summary of roles and responsibilities for vestries as well as for officer bearers (<https://www.scotland.anglican.org/vestry-resources/vestry-responsibilities/>) and the Diocese holds Trustee Training Days at least twice a year – to which you and your vestry are strongly encouraged to attend.



Each individual church, or group of churches if a joint charge, will have its own constitution. You can find examples of model constitutions on the SEC website:

<https://www.scotland.anglican.org/vestry-resources/vestry-responsibilities/model-constitutions/>.

Each charge is also a charity in its own right and must be compliant with the Scottish Charity regulator, OSCR <https://www.oscr.org.uk/>.

Some charges have two Church Wardens. The "People's Warden" is elected annually by the AGM, while the "Rector's Warden" is appointed by the Rector. Some of the roles of Wardens will be similar to those in the CofE. However, unlike the CofE, the Church Warden does not have a specific remit for looking after the church property.



In the SEC, there is often a property convenor who will look after the church and the rectory property. This is an important difference: your Vestry will also be responsible for your Rectory upkeep and for direct payment of the sorts of bills that the diocese would normally pay for the upkeep of a vicarage in the CofE. Your property convenor, and not the diocese, will arrange visits from plumbers, builders, etc.



The Secretary is a key member of Vestry and meeting agendas, and other Vestry business should be worked out in consultation with them.

You will have a treasurer, as you would expect. The financial year for each charge is defined by their constitution, with the vast majority running from 1st September to 31st August. AGMs must take place within 3 months of the end of financial year in accordance with OSCR regulations. As a result, most congregations will have their AGM in late November/early December, but yours might be slightly earlier. Ultimately check your constitution!

You may have a paying officer to help the treasurer by paying ongoing bills or the two offices will be combined. Notice that the Vestry will pay your stipend and pension rather than the Diocese, some charges pay the diocese / SCVO to do payroll. This is a very important difference. As a result, the share (quota) that each charge pays the Diocese is much lower than in the CofE and nowhere near as significant an item of expenditure. Ideally you would also have a Gift Aid secretary who may or may not be a member of the Vestry.

Another difference is that you will have a Lay Diocesan Synod Rep and an Alternate Lay Rep on the Vestry. Each church elects their own Lay Reps for Diocesan Synod, rather than them being elected indirectly. Both Lay Rep and Alternative Lay Rep are members of vestry.

Each church needs to have a PVG (Protection of Vulnerable Groups) Co-ordinator, who may or may not sit on the Vestry, and who has an identical role to the CofE DBS equivalent. All members of vestry should be aware of PVG requirements and attend regular training. For more information about safeguarding, see p16.

You can find more information about Vestries and their work on the Diocesan website <https://edinburgh.anglican.org/diocesan-office-resources/vestries/> and in Canon 60.

Every year you must hold an Annual General Meeting (this may be on the Feast of Christ the King, or thereabouts, depending on your constitution) and give notice at least 3 weeks beforehand. The conduct and content of the AGM will be pretty much the same as it would be in the CofE. Having been approved by the Vestry, the Annual Accounts will be presented at the AGM, and reports given by Office Holders.

YOUR WELLBEING

The SEC takes the wellbeing of its clergy very seriously and in recent years has introduced the expectation that you should have 2 complete days off work every week. Please see here for the Clergy Personnel Handbook (<https://www.scotland.anglican.org/vestry-resources/clergy-personnel-handbook-introduction/>).

The Diocese can advise on Spiritual Directors and on Retreat Houses. Have a look at our website and contact the Advisor for Christian Living for more information.

https://edinburgh.anglican.org/dmmc_resources/spiritual-direction/ and <https://edinburgh.anglican.org/adventures-in-faith/retreat-venues/>.



There are a wide range of worship traditions within the SEC: evangelical, catholic, liberal and "middle of the road". The canons stipulate that Holy Communion should be celebrated in every SEC church on every Sunday unless otherwise agreed with the Bishop, and therefore the Sunday Eucharist is the mainstay of worship in most churches; this is one thing that differentiates the SEC from the Church of Scotland.

The liturgy for the Eucharist is most likely to be drawn from the Blue Book (Scottish Liturgy 1982). Updated additions and variations (including non-gendered language) have been published by the Faith and Order Board, most recently in 2022. The Scottish Book of Common Prayer (1929) and the 1970 version of the liturgy are also available. Some may choose to offer one of these alternatives at early Sunday services or mid-week.

The theological influence of the Orthodox tradition has been more significant in the SEC than in the CofE. Some examples of this are the omission of the *filioque* clause in the 1982 version of the creed and, at a more obviously practical level, the admission of children to Holy Communion after baptism. There is no general guidance in the SEC that children will need to wait to the age of 6 or 7 to be instructed before receiving a First Communion, and with parental permission may receive at least the consecrated wafer from baptism, whatever their age.

Another important difference from the CofE will be the lectionary. The SEC generally follows the Revised Common Lectionary but has its own optional variations such as a selection of readings for Remembrance Sunday and the Scottish saints. It will be different from the Common Worship Lectionary; although, as both largely follow the RCL, there will be a large overlap. The SEC also has its own collects and post-communion prayers, though there is a Book of Alternative Collects which are extremely similar to the Common Worship ones.

The seasons are largely the same, and although the more recent CofE variations of a Kingdom Season and an Epiphany Season may not be kept, they have sometimes been adopted. Certain saints may have more significance and Celtic traditions of worship may be more important for some, though as in the CofE these things vary. The full range of the SEC's liturgies can be easily seen and downloaded on the website:

<https://www.scotland.anglican.org/who-we-are/publications/liturgies>

SOME ASPECTS OF INCLUSION

There are some differences in church-life around some areas of "inclusion". Firstly, it is now possible for same-sex couples to be married in the SEC. As in the CofE, there is a range of views on this subject and clergy need to specifically apply to their Bishop for permission to conduct same-sex weddings, alongside a system of vestry consultation before permission is granted (see below under *Weddings*).

Secondly, all three orders of ministry are open to women and men equally. Unlike the CofE, there is no opt-out from Episcopal oversight where the bishop is a woman. The priestly and episcopal calling of women has been wholeheartedly embraced in the SEC, although in practice this is not yet fully reflected in the membership of the College of Bishops.



DIOCESAN YOUTH WORK

At a diocesan level, the Advisor for Christian Life (ACL), Fee Reynolds, is available to support all clergy and charges in their ministry to children, young people and families. She can advise on resources, working with volunteers, and running activities such as Messy Church and Godly Play. She also works closely with churches on the appointment of salaried youth and children's workers and acts as an external mentor to these workers. Small grants are available for youth and children's work.

In addition to this, the diocese runs a programme of youth events for 12-18 year olds throughout the year, which provide an opportunity for

young people across the diocese to come together and spend time playing games, hanging out and exploring faith. For all enquiries related to Diocesan Youth and Children's work, please contact the Advisor for Christian Life.

The Diocesan Youth and Children Newsletter can be found here: <https://edinburgh.anglican.org/youth-and-children-newsletter/>

PLAY CHURCH

Play Church is an initiative which is unique to Edinburgh Diocese. It is a child-sized altarscape with everything children need to learn, through play, about what they see happening during worship. The Play Church is on a permanent pilgrimage around the diocese, visiting three charges a year. For more information, visit the Play Church pages of the website: <https://edinburgh.anglican.org/play-church/>



SCHOOLS WORK

There is no Scottish equivalent of the CofE Primary School so for Scottish churches of all denominations, schools work is dependent on building relationships at a local level. Scripture Union Scotland (which is related to, but separate from, Scripture Union UK) is very active in schools, but has no specific affiliation to any denomination. SU Scotland is also a popular provider of holiday clubs for children and young people and many charges use their material to run their own or local ecumenical holiday clubs:

<https://www.suscotland.org.uk/about-us/faqs/>

If you have come from the Church of England, you may have enjoyed working in partnership with your local CofE school. For Scottish Episcopal clergy, developing relationships with local schools is likely to be much more of a challenge due to a lack of 'entitlement' to engage in collective worship, time for reflection, etc, in schools. This may also have a bearing on the number of young families attending your church in comparison to some CofE congregations, which may be heavily populated with those who are hoping to qualify for a Church School place.

It is worth noting other national organizations also have a specific Scottish identity, such as Christian Aid Scotland and Godly Play Scotland.

PROVINCIAL YOUTH WORK

The Provincial Youth Committee comprises youth officers and youth representatives (12-18 and 18+) from each of the seven dioceses. Young members have, for example, sat on Provincial Working Groups and Preparatory Committees for new diocesan Bishops. They have also represented the SEC internationally. PYC events are well attended by young people across the Province: these are usually weekend sleepovers in local churches, where all the gathered young people help to lead worship on the Sunday morning. If your church would like to host a Provincial Youth Sleepover, please contact the ACL in the first instance.

Yeek is the annual Provincial Youth Week, held at Glenalmond College in Perthshire every summer (also affectionately known as “Glen”). It brings together young people (“delegates”) from all over Scotland for a week of fun, faith, and fellowship.

Further information about Yeek is available from Claire Benton-Evans, who is a Yeek leader and also the Provincial Youth Committee Enabler: ClaireBE@scotland.anglican.org





Occasional Offices

WEDDINGS

In Scotland the officiating priest is not the registrar of a marriage, but represents the registrar. It is the responsibility of the couple to get a Marriage Schedule, without which, you cannot marry them. All the information you need can be found at:

<https://www.nrscotland.gov.uk/registration/i-want-to-get-married-in-scotland-how-do-i-go-about-it>.

The liturgy for marriage offers lots of variety so you can spend some time with the couple going through all the options and let them choose which bits they like best. It is a good idea to have the couple bring the Marriage Schedule to the rehearsal and leave it with you. They get it from the local Registrar close to the venue. The signed Marriage Schedule (and related document) **must** be returned to the relevant Registry Office within 3 calendar days of the marriage – this is the couple's responsibility.

Our Bishop prefers that couples get married in church but, in very exceptional circumstances, may allow it to be held elsewhere. You will need to write a letter to him to ask his permission to do so. Likewise, if one or both of the couple are divorced, there is a procedure to follow under Canon 31 and a form to fill in, which may be obtained from the Bishop's PA. The Bishop also expects you to provide information about the couple and the reasons for the divorce(s) in a covering letter. If you are asked to marry a couple in a venue which is not in your 'patch' it is considered appropriate to inform the local SEC priest.

Depending on the demographic of your congregation, marriages can be extremely rare, unless your church is particularly picturesque in which case you may have more than your fair share.

The marriage of same-sex couples is permitted under Canon 31. You may not conduct such a marriage unless you have been nominated to do so by the Bishop. The process for nomination is explained in detail in the notes to Canon 31 (obtainable from the diocese or GSO) which explain that no clergyperson will be nominated unless they have the agreement of their Vestry.

FUNERALS

If you come from the CofE, you may find that you have fewer funerals to conduct and that, when you are asked to do one, there will be a specific link with your charge, the SEC, or the Anglican Communion. Sometimes funeral directors will assume that, as you are not Roman Catholic, you will want to conduct a funeral in a more Presbyterian manner. For example, the coffin may be completely covered with a pall at the start of a service and sometimes not processed in. If there are more "catholic" elements of ritual that you feel are important and helpful, you may need to negotiate these with the bereaved and the funeral directors beforehand.

It is often the case that churches are a distance from crematoria. As such, it is increasingly common for 'church funerals' to comprise of a small family service at the crematorium, followed by a thanksgiving service at the church. Receptions also tend to follow thereafter.

There will, of course, be local customs at burials which may be good to know about. Ask your buddy! Situations will vary depending where you are but you may find that you have fewer funerals or at least fewer funerals which do not involve someone with some link with your charge.

BAPTISMS

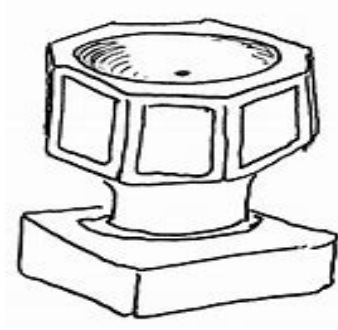

Children can receive Holy Communion after baptism at the discretion of their parents. Canon 25 specifies that 'The Sacrament of Baptism is the full rite of initiation into the Church, and no further sacramental rite shall be required of any person seeking admission to Holy Communion'. Nevertheless, some young people and adults seek to reaffirm their baptismal promises with the laying on of hands (the Liturgy is called Affirmation of Baptism Vows, but is still often referred to as Confirmation). The bishop is always happy to be invited to officiate at such ceremonies.

The liturgy of Affirmation of Baptism Vows can be used at different points in someone's life: after life changes, if they return to church after time away, or to mark a renewed discipleship.

EXPENSES FOR OCCASIONAL OFFICES

Clergy are not allowed to charge for conducting occasional offices. We can accept donations. Recommended costs are fixed by the Scottish Federation of Organists for musical contributions to occasional offices.

PASTORAL OFFICES

There are liturgical booklets for Deacons and Priests which cover the following circumstances (as appropriate):

- Baptism outside Public Worship (including emergency baptism).
- Welcome into the Congregation of Persons baptised outside Public Worship.
- Reconciliation of a Penitent.
- Holy Communion from the Reserved Sacrament outside Public Worship with Laying-on of Hands and Anointing of the Sick.
- Ministry with the Dying.
- Prayers with the Family at the time of bereavement.

Electronic versions of these booklets are available online:

- <https://www.scotland.anglican.org/wp-content/uploads/Pastoral-Office-for-Priests.pdf>
- <https://www.scotland.anglican.org/wp-content/uploads/Pastoral-Offices-for-Deacons.pdf>



Administrative

REGISTERS

All church registers must be kept up to date. These will be checked by the Dean when she does her visitation every 4 years according to Canon Law (See Canon 42). You must also keep a record of all Services in the register as you will need the numbers gathered by the church for your annual returns due at the beginning of Advent every year. It is the incumbent's responsibility to ensure that these numbers are recorded and submitted.

CONGREGATIONAL ROLL

The Congregational Roll contains the names of people who regularly attend weekly worship in your church. If someone is not a regular worshipper and only comes to church occasionally, their name should be placed on the Adherent's Roll instead. This also applies to all the grown-up children whose parents want them to remain as 'members' of the church.

ANNUAL RETURNS

Each charge must submit a selection of forms to the diocese every year, usually due after the Feast of Christ the King. These include congregational statistics, audited accounts, finance schedules and a diocesan schedule. More information about these forms can be found on the website, and communication about when they are due is made through the diocesan magazine *The Communicant*.

CANON 35

Canon 35 is the canon relating the church buildings and fabrics. It stipulates that to make any permanent or significant changes to a church's building or fabric, including graveyards and gardens, permission must be sought through the diocesan buildings committee. There is an application process which may involve the committee visiting the building to view the proposed changes. If the committee grants permission for the changes to be made, there is a three-year period the work can be completed in without having to submit a further Canon 35 application. There are very few changes churches can make which are not subject to Canon 35 approval.

SAFEGUARDING

Both the Diocese and the SEC takes safeguarding concerns very seriously. From 1 July 2025, any person working in a regulated role **must** be a member of the PVG Scheme. Both the individual and the church commit a criminal offence otherwise.

If you have questions about practice, please use the Diocesan Protection Officer, Hannah Marcus, as a first point of contact.

Email: HHarcus@dioceseofedinburgh.org.



There is training available, organised primarily the GSO. The Provincial Safeguarding Officer is John Wyllie
Tel: 07881 868 387 Email: safeguarding@scotland.anglican.org.

GDPR

The SEC website contains sample forms and policies for ensuring that the data you hold is held securely and legally. The guidance can be found here <https://www.scotland.anglican.org/vestry-resources/general-information/data-protection/>

SUPPORT FROM THE DIOCESAN OFFICE

The Diocesan Office is open Monday-Friday 9am-5pm. Staff in the office provide a range of support and resources which can be useful for different aspects of church life. The fortnightly magazine, *The Communicant*, is sent to all clergy and vestry officers, and contains important information about administrative matters applying to churches around the diocese. In addition, there is a DMMC Newsletter which goes out once a month to all in authorised ministry, sharing news and upcoming events around the diocese. A regular Youth and Children's Update is accompanied by a biannual Youth and Children's newsletter which celebrates Youth and Children's work around the diocese. All members of the Diocese are encouraged, where able, to receive the monthly email 'Adventures in Faith', which highlights various opportunities to explore their faith in a range of different ways. All publications are available to view on the diocesan website.

The Communicant: edinburgh.anglican.org/publications/the-communicant/

DMMC News: edinburgh.anglican.org/publications/dmmc-news/

Y&C Update and Y&C Newsletter: edinburgh.anglican.org/publications/youth-and-children-newsletter/

Adventures in Faith: edinburgh.anglican.org/publications/adventures-in-faith-newsletter/

There is also a range of clergy and vestry support available on the website, including resources for worship and vestry officer forms. Additionally, the diocesan support forum provides a platform for people around the diocese to contact each other and ask questions/receive answers from people who have had experience with areas of difficulty in the past. There is currently a separate forum for buildings convenors, church administrators, PVG coordinators, vestry secretaries, and vestry treasurers.

The diocesan office can also assist with printing/photocopying, and can print up to A3, banners, booklets, and posters, in both black-and-white and colour.





Ministerial Support

BUDDY

When you come to the Diocese of Edinburgh, the Synod Clerk will be in touch with you to match you up with a Buddy. They will usually be a priest who lives nearby and will buddy you for your first year. They will be your first point of contact for any questions not contained in this booklet. You will also be assigned a Chapter Canon – one of the senior clergy of the diocese – who will be able to offer advice. Charges that have received major funding from the Investing in the Future initiative will have a Diocesan Companion instead.



CONTINUING MINISTERIAL DEVELOPMENT (CMD)

The Advisor for Christian Life, in conjunction with the Diocesan Ministry and Mission Committee (DMMC), is responsible for CMD. Various events are offered throughout the year which you are strongly encouraged to attend, not least because it is a great opportunity to meet up with your colleagues: most clergy attend most of the Diocesan CMD events. Our events include 2 or 3 one-day events per year, as well as more informal gatherings throughout the year. In November we get together for a 4-day Diocesan residential, the 'Clergy Conference', which is open to Stipendiary and active Self-Supporting Clergy. We also offer lunch time meetings in the Diocesan Office or on Zoom on different topics. Look out for information in emails from the DMMC, and in the Communicant.

MINISTERIAL REVIEW

A major part of the life-long learning and development for all in stipendiary ministry is the Bishop's Ministerial Review. This enables us to reflect on our ordination promises and at the particular context for our ministry. It is a collegial process of peer support and reflection.

In discussion with the bishop, the ACL will arrange for a reviewer to meet with you. The forms are invitations to reflection and will provide the basis for what you would like to share with your Reviewer. A summary of your discussion is shared with the Bishop. An Action Agreement is also completed, which can be shared with the ACL, if you wish support to implement your Action Points. Both these forms are confidential. You can explore the paperwork here: edinburgh.anglican.org/dmmc_resources/ministerial-review/.

The Ministerial Review has proved to be very supportive as we encourage each other in our ministry.

This is just a rough guide to help you settle into the Diocese of Edinburgh. If you have any questions then please speak to your Buddy or contact the ACL (Revd Fee Reynolds freynolds@dioceseofedinburgh.org) or other members of the Diocesan Office. No question is too daft!

We wish every blessing upon you in this new ministry, and we look forward to getting to know you!